



Web

Quintin Jackson

Self-Branding

Research Personal Identity

Target Audience

The target audience is broken down into two groups, Potential employers from development firms and clients for freelance jobs. The web development firms targeted delve in the core languages of HTML5, CSS3, Javascript, PHP5, JQuery, and MySQL. As for freelancing jobs, the more diverse your skill-set, the greater chance you will get those jobs since none are exactly the same.

Personal Brand Statement

Many people face many different business problems on the web, whether it be building a web presence or redesigning your existing one. When you need someone who knows how to handle your web problems, QWeb is the one you need by your side. From design and front-end coding to back-end and SEO, QWeb handles it all.

Defining Qualities

- Passionate toward all coding, especially PHP and JavaScript.
- Excel more in development than design.
- Enjoy the piecing of parts together to make a website.
- Experience in a wide variety of fields of design and development. Additional experience in photography, image manipulation, marketing, and advertising.



Self-Branding

Personal Brand Construction

Business Name Ideas

1. Q Web
2. QJ Web
3. QBJ Web
4. Q Webster
5. QJ Webster
6. Gallant Coding
7. QJ Program
8. QJ Programming
9. Bryce Programming
10. Jackson Coding
11. Jackson Programming
12. Jack of all Web
13. Jack o' Web
14. Jacko Web
15. Bryc Coding
16. Bryc in the Web
17. Noble Coding
18. Noble Knight Coding
19. Boolean Web Coding
20. QBJ Web Solutions
21. Kombat Koding
22. Code-out Solutions
23. Web Engine
24. Coding Domain
25. HCJP Coding

Final Business Name and Domain

- QWeb
Web Designer and Developer
www.qweb.com

Although there are many fun and interesting ways to make a brand for yourself, simplicity makes brands easier to remember.

Descriptive Words

Trustworthy, Reliable, Determined, Careful, Vigilant, Respectful, Adamant, Studious, Magnanimous, Solemn, Perfectionist, Optimistic, Tenacious, Resolute, Determined, Supportive, Loyal, Compassionate, Attentive, Programmer, Designer, Enthusiastic, Cautious, Patient, Polite, Perceptive, Understanding, Planner, Organizer, Cooperative, Keen, Vigorous, Builder, Creator, Constructor, Industrialist, Modern, Noble, Gallant, Suave, Gracious, Sophisticated, Distinguished, Polite, Respectful, Dedicated, Dependable, Responsible



Quintin Jackson | Web Developer | qweb.com

Self-Branding

Personal Brand Logo

Logomark Thumbnails

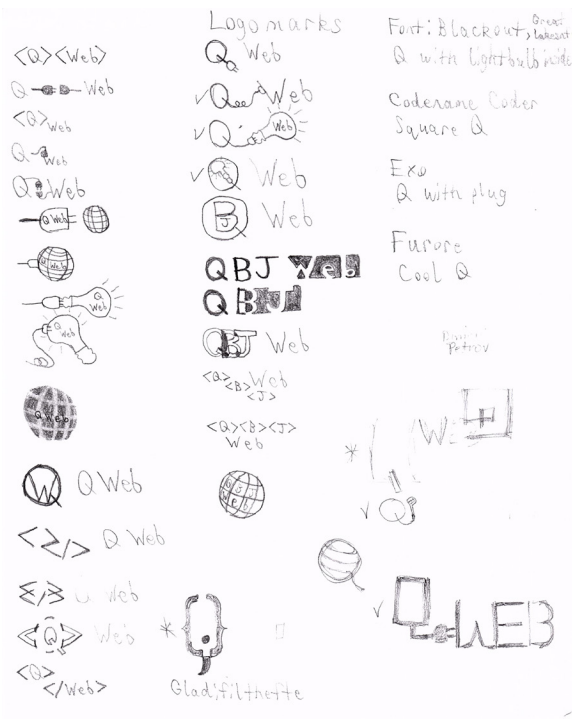

Logotype Thumbnails

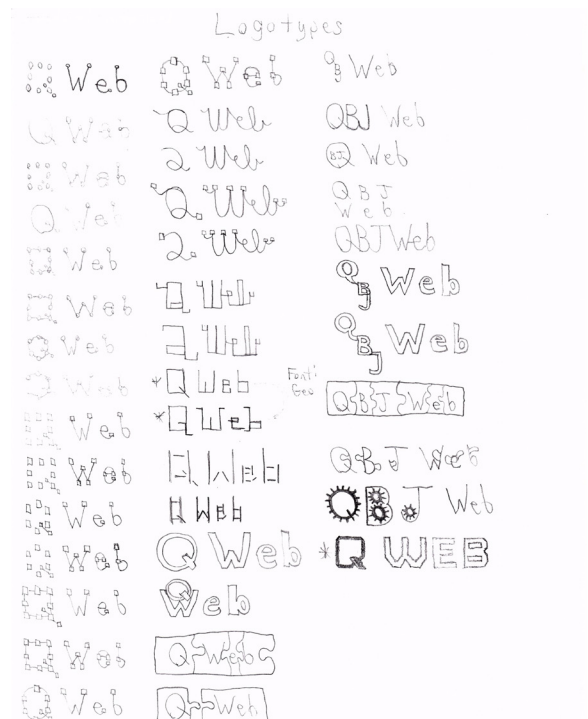

Self-Branding

Personal Brand Colors

Color Palletes



R 0, G 51, B 153
Hex #003399

R 51, G 102, B 204
Hex #0099CC

R 202, G 151, B 49
Hex #CA9831

R 204, G 204, B 204
Hex #474747



R 0, G 51, B 153
Hex #003399

R 51, G 120, B 204
Hex #3366CC

R 102, G 153, B 204
Hex #6699CC

R 255, G 201, B 0
Hex #FFCC00



R 0, G 51, B 153
Hex #003399

R 51, G 0, B 102
Hex #330066

R 0, G 153, B 102
Hex #009966



R 153, G 0, B 0
Hex #990000

R 51, G 51, B 51
Hex #333333

R 204, G 204, B 204
Hex #CCCCCC



R 0, G 51, B 153
Hex #003399

R 0, G 204, B 0
Hex #00CC00

R 255, G 51, B 51
Hex #FF3333

R 255, G 204, B 102
Hex #FFCC66



Self-Branding

Final Branding Style



R 0, G 51, B 153

Hex #003399 C 100, Y 91, M 6, K 1



R 51, G 102, B 204

Hex #0099CC C 78, Y 24, M 6, K 0



R 202, G 151, B 49

Hex #CA9831 C 21, Y 40, M 97, K 2



R 204, G 204, B 204

Hex #474747 C 66, Y 59, M 58, K 41



Minimum Height Size: 0.375 in.



Quintin Jackson | Web Developer | qweb.com



Non-Interactive Piece

PCBuilders

[Logo](#)

Software Used:
Adobe Illustrator

[Description](#)

You would be surprised how far a touch of orange goes with blue. Utilizing white space on both the left and right of the screwdriver in two completely different ways made it more interesting to look at.



Quintin Jackson | Web Developer | qweb.com

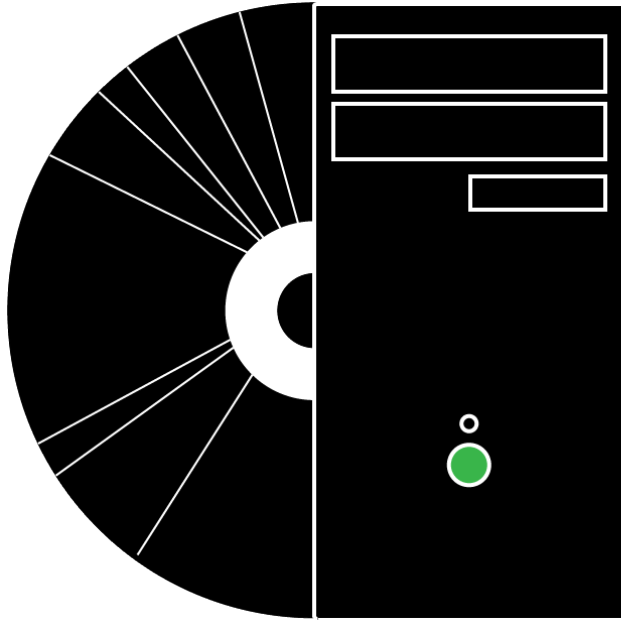

PC Gamers' List

Non-Interactive Piece

PCGamersList

Logo

Software Used:
Adobe Illustrator

Description

Keeping the logo in black and white better emphasizes the small negative spaces in-between the pieces. Since this computer reminds me of the older desktop models, I put green in the power button as if the computer was on. The "half" CD is another reference to PC gaming, but combined with the tower to make it more artistically appealing.



Quintin Jackson | Web Developer | qweb.com



Non-Interactive Piece

VidItYourself

Logo

Software Used:
Adobe Illustrator

Description

Even though the purpose of the website is more modern, I felt compelled to use an older concept. The circular movie camera lens projecting to the bottom-right gave the logo a nice simplicity compared to designs from the modern sources of video like TV and the internet.



Quintin Jackson | Web Developer | qweb.com

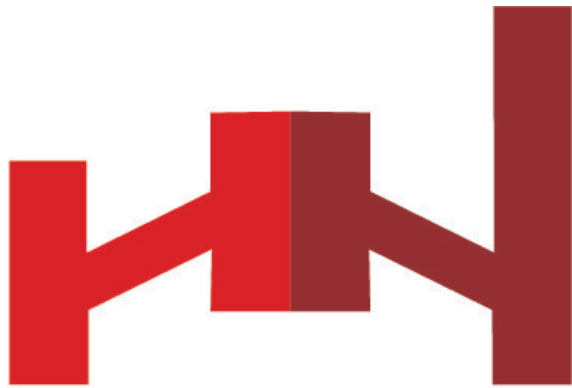

Hail House
House of the Odd and Extrordinary

Non-Interactive Piece

Hail House

Logo

Software Used:
Adobe Illustrator

Description

This one in particular encouraged me to experiment with the typography of the abbreviation. Turning the abbreviation into a house takes some imaginative thinking, but still works without going over people's heads.



Quintin Jackson | Web Developer | qweb.com



Non-Interactive Piece

All American Restaraunt

[Logo](#)

Software Used:
Adobe Illustrator

[Description](#)

Even though this is a logo for a website, I imagined a logo that you could put on a restaurant menu and a sign on top of the restaurant as well. Having the stars be blue was tested before, but wasn't an effective accent color. Even without the blue, the typography and curved banner with stars gives the logo a patriotic American feel.



Quintin Jackson | Web Developer | qweb.com

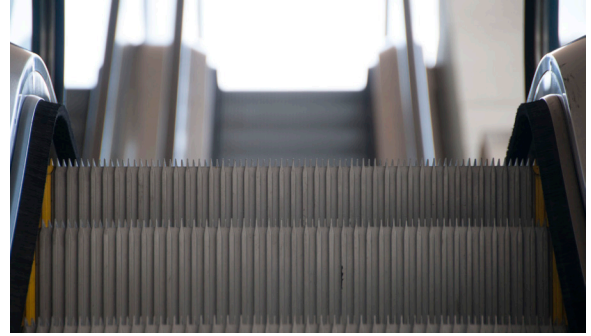

Non-Interactive Piece

Photography

Architecture Photos

Software Used:
Adobe Photoshop

Description

These pictures were taken around the shopping district of Park Lane. The objects that frame the architecture are what make this set interesting to look at. Depth of field further helped with accentuating the surrounding architecture.



Quintin Jackson | Web Developer | qweb.com



Non-Interactive Piece

Photography

Suburban Photos

Software Used:
Adobe Photoshop

Description

Photos shot in the city of Carrollton, Texas based around the scenery of the suburban town. There was a difficult time taking pictures of interesting subjects located in these areas. Many of these shots required multiple takes and positioning of the subject and elements.



Quintin Jackson | Web Developer | qweb.com

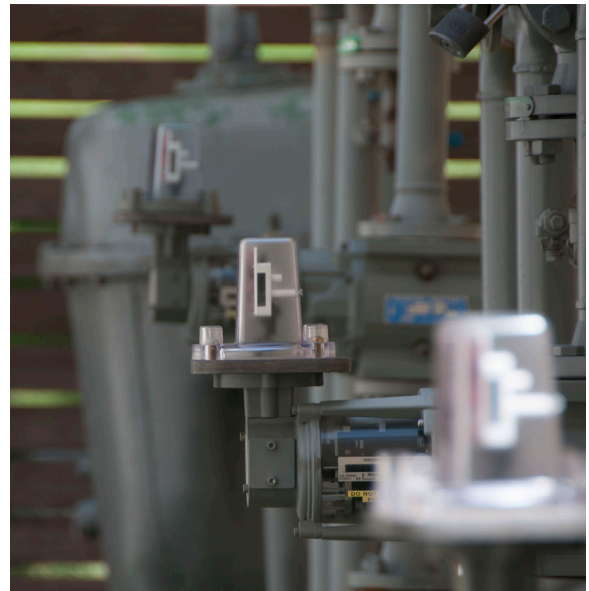

Non-Interactive Piece

Description

Photography

Urban Photos

Software Used:
Adobe Photoshop

Introducing a montage of photos centered around objects and environments located in the city of Dallas, Texas. Using alignment and a large depth-of-field is what helped inspired this set.



Quintin Jackson | Web Developer | qweb.com



Non-Interactive Piece

All American Restaurant

Restaurant Poster

Software Used:
Adobe InDesign

Description

Marketing via posters is a great way to expand on typography and layout. What was very interest was implementing an american, patriotic theme to a restaurant without the feeling of government propaganda.



Quintin Jackson | Web Developer | qweb.com



Non-Interactive Piece

All American Restaurant

Restaurant Menu

Software Used:
Adobe InDesign

Description

This project was a very unique way to test designing ability outside of web. It was interesting to experiment with layout, typography, and color. Since the logo already has racecar red in it, white and blue was needed to balance the color scheme.



Quintin Jackson | Web Developer | qweb.com

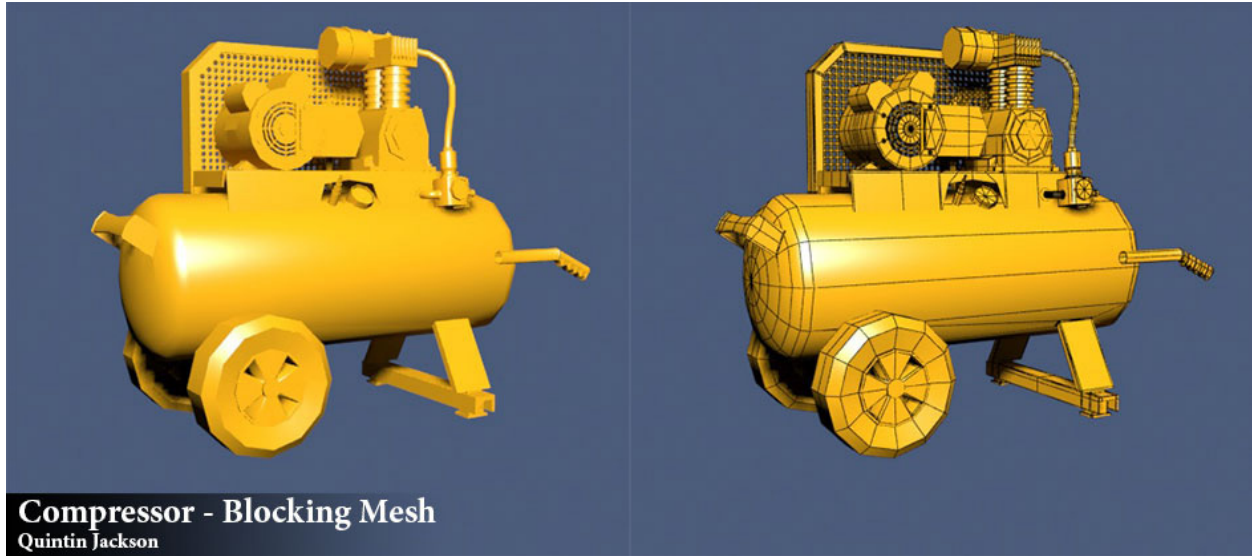

Non-Interactive Piece

Compressor Model

[3D Model](#)

Software Used:
Autodesk 3DS Max

Description

Luckily, most of the pieces of the object are solid and didn't require many polygons. As I worked my way up, the pieces with many holes like the motor and back-plate was much harder to construct efficiently. The motor was especially awkward due to its fusion of cylinder and rectangle shapes.



Quintin Jackson | Web Developer | qweb.com

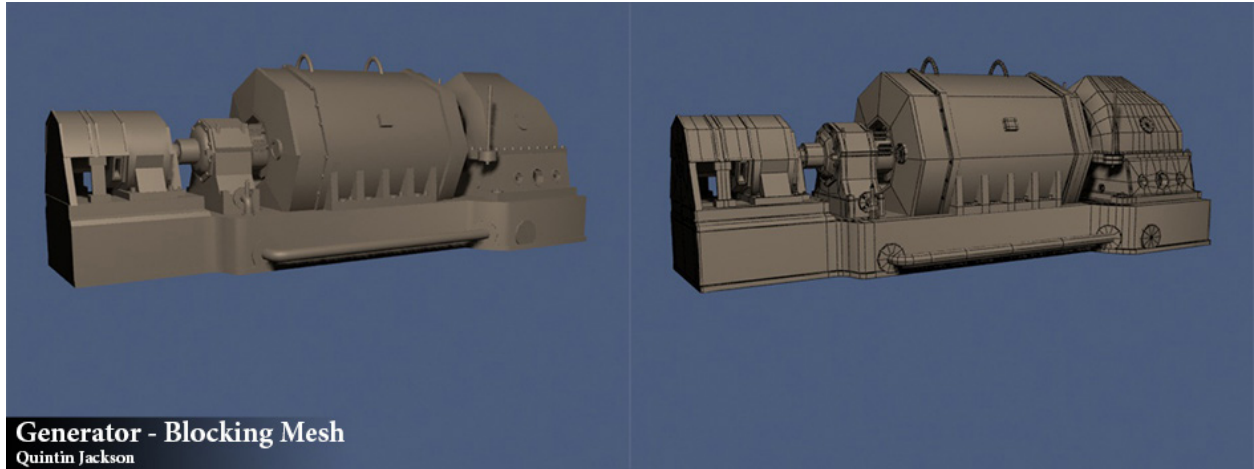

Non-Interactive Piece

Generator Model

[3D Model](#)

Software Used:
Autodesk 3DS Max

Description

Much of this object consists of is cylinders atop of a rectangle base. The archway towards the back was particularly difficult because it has its own rectangular bases with holes and the arch narrows towards the apex. Smaller pieces proved even more difficult to keep the polygon count low when making the budgetted low-poly model.



Quintin Jackson | Web Developer | qweb.com

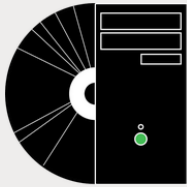

PC Gamers' List

[Home](#) [PC Games List](#) [New Games](#) [Top Rated Games](#) [Contact Us](#)

Welcome to the go-to website for PC games



Welcome to pcgamerslist.com, a community website dedicated to informing the public of all of the available PC games out there in existence. This website has an entire list of information about the many PC games that have been made and is accessible by the public.

No account or purchase is necessary to access this information, so feel free to browse around and hopefully you will find a cool PC game for yourself or someone else to play.

Part of what makes this site different than the others is it's dedication to PC games. Another important feature of this site is that it is the USERS that create the information for the games. Users can simply fill out a form for a game not listed in the website and submit the game's title, age rating, release date, cost, genre, and description.

Once the form has been submitted, the new PC game will be posted on the website in the games list, where you can view this information by clicking on the name of the game. If you have played a PC game and would like to share on how awesome, or not, the game is, you can rate the game on the scale of 1.0 to 10.0. You can also leave a comment about the game as well. In the games list, all of the PC games are listed in a table.

The games can be organized in ascending or descending order by name, genre, average user rating, ect. There is also a contact

Interactive Piece

PC Gamers List

Website

Software Used:

HTML 5

CSS 3

PHP 5

MySQL

Description

Being a gamer myself, I wanted to create a website about computer games that would be helpful to the users. Building a computer game database can by myself would be time-consuming. Creating a user-generated table would not only solve that problem, but make the site more interactive and interesting. Unlike other websites like this one, user login isn't required to do any of these things. At the very least their would have to be a moderator to confirm the entries and delete inappropriate ones.



Quintin Jackson | Web Developer | qweb.com

PC Gamers' List

Home PC Games List New Games Top Rated Games Contact Us

Game List

Don't see a PC game in the system? [Click Here to Add a Game](#)

Welcome to pcgamerslist.com, a community website dedicated to informing the public of all of the available PC games out there in existence. This website has an entire list of information about the many PC games that have been made and is accessible by the public. No account or purchase is necessary to access this information, so feel free to browse around and hopefully you will find a cool PC game for yourself or someone else to play. Part of what makes this site different than the others is its dedication to PC games. Another important feature of this site is that it is the USERS that create the information for the games.

SELECT * FROM Game ORDER BY Name ASC

Name	Genre	Age Rating	Cost	Release Date	Average User Rating	Number of User Ratings
Age of Empires III: Complete Collection	Strategy	T - Teen 13+	\$39.99	09/15/2009	8.5	3
Assassin's Creed 2	Action/Adventure	M - Mature 17+	\$19.99	03/09/2010	9	3
Assassin's Creed: Brotherhood	Action/Adventure	M - Mature 17+	\$19.99	03/17/2011	9.1	3
Call of Duty 4: Modern Warfare	Shooter	M - Mature 17+	\$19.99	11/05/2007	9.4	3
Counter-Strike: Global Offensive	Shooter	M - Mature 17+	\$14.99	08/21/2012	9.3	3

PC Gamers' List

Home PC Games List New Games Top Rated Games Contact Us

Game List - New Games

Don't see a PC game in the system? [Click Here to Add a Game](#)

Welcome to pcgamerslist.com, a community website dedicated to informing the public of all of the available PC games out there in existence. This website has an entire list of information about the many PC games that have been made and is accessible by the public. No account or purchase is necessary to access this information, so feel free to browse around and hopefully you will find a cool PC game for yourself or someone else to play. Part of what makes this site different than the others is its dedication to PC games. Another important feature of this site is that it is the USERS that create the information for the games.

SELECT * FROM Game ORDER BY ReleaseDate ASC

Name	Genre	Age Rating	Cost	Release Date	Average User Rating	Number of User Ratings
Empire: Total War	Strategy	T - Teen 13+	\$14.99	03/03/2009	0	
South Park: The Stick of Truth	Roleplaying	M - Mature 17+	\$59.99	03/04/2014	0	
Assassin's Creed 2	Action/Adventure	M - Mature 17+	\$19.99	03/09/2010	0	
Assassin's Creed: Brotherhood	Action/Adventure	M - Mature 17+	\$19.99	03/17/2011	0	

PC Gamers' List

Home PC Games List New Games Top Rated Games Contact Us

Contact Us

Welcome to pcgamerslist.com, a community website dedicated to informing the public of all of the available PC games out there in existence. This website has an entire list of information about the many PC games that have been made and is accessible by the public. No account or purchase is necessary to access this information, so feel free to browse around and hopefully you will find a cool PC game for yourself or someone else to play. Part of what makes this site different than the others is its dedication to PC games. Another important feature of this site is that it is the USERS that create the information for the games.

First Name:

Last Name:

Email:

Confirm Email:

Please leave your issues/concerns below:

Use your message here. Use content and complete sentences with appropriate punctuation and clear abbreviations.

PC Gamers' List

Home PC Games List New Games Top Rated Games Contact Us

Game List - Top Rated

Don't see a PC game in the system? [Click Here to Add a Game](#)

Welcome to pcgamerslist.com, a community website dedicated to informing the public of all of the available PC games out there in existence. This website has an entire list of information about the many PC games that have been made and is accessible by the public. No account or purchase is necessary to access this information, so feel free to browse around and hopefully you will find a cool PC game for yourself or someone else to play. Part of what makes this site different than the others is its dedication to PC games. Another important feature of this site is that it is the USERS that create the information for the games.

SELECT * FROM Game ORDER BY AverageUserRating ASC

Name	Genre	Age Rating	Cost	Release Date	Average User Rating	Number of User Ratings
Portal 2	Shooter	E10 - Everyone 10+	\$29.99	04/19/2011	0	
The Sims 3 Late Night Expansion Pack	Simulation	T - Teen 13+	\$19.99	10/26/2010	0	
Call of Duty 4: Modern Warfare	Shooter	M - Mature 17+	\$19.99	11/05/2007	0	
Minecraft	Roleplaying	E10 - Everyone 10+	\$26.95	11/18/2011	0	

PC Gamers' List

Home PC Games List New Games Top Rated Games Contact Us

Game Entry Form

Welcome to pcgamerslist.com, a community website dedicated to informing the public of all of the available PC games out there in existence. This website has an entire list of information about the many PC games that have been made and is accessible by the public. No account or purchase is necessary to access this information, so feel free to browse around and hopefully you will find a cool PC game for yourself or someone else to play. Part of what makes this site different than the others is its dedication to PC games. Another important feature of this site is that it is the USERS that create the information for the games.

Name:

Age Rating:

Release Date:

Cost:

Genre:

Description:

Use the description of the game here. Describe as much of what the game is about as much as you can without revealing any spoilers to the game's story. Use content.

PC Gamers' List

Home PC Games List New Games Top Rated Games Contact Us

The Elder Scrolls V: Skyrim

Genre:

Age Rating:

Cost:

Release Date:

Average User Rating:

Number of Ratings:

[Click here to Rate and Comment](#) this game



Learn How to Build Computers

PCBuilders.com - dedicated to educating users on how to build their own computer.

This website has useful information about PC components, how they work & what they do.



Interactive Piece

Description

PC Builders

Website

Software Used:

HTML 5

CSS 3

JQuery

PHP 5

Even though computer technology has become common nowadays, there are still many people who that don't know how to build there own computer. To make this website stand out, I included various images, detailed instructions and tips on what parts to put into their computer. Different people need different computers, so it is important to inform the users of what parts they would need and how to install them. I also put in a comments section as a way for users to communicate and help one another. A moderator would be needed to facilitate the comments.



PC Builders Site Map
 Search by page name

Home Why Should I? Components Build a PC Contact

Why Build My Own PC?



Since we have so many things going on in our lives we tend to take shortcuts when we don't have the time to deal with something. Over the years personal computers have become more and more important part in our daily lives. This makes us constantly rethink what we use computers for as they change every year.

As newer technologies become available to the public, the computers themselves change as well. This is why learning how to update and modify your computer to what you need as time moves on is very important. Even your job may require you to use a computer with higher end or special components that aren't normally sold in the standard market.

Learning how to build your own computer gives you the freedom to build whatever kind of computer you want with any compatible parts. You can also freely upgrade and attach new components that you need later. While computers that you buy don't allow you to modify or even open them without voiding a warranty.

Post Comment

Type your comments about this article here. Use coherent and complete sentences with preferably no typos or misspellations.

PC Builders Site Map
 Search by page name

Home Why Should I? Components Build a PC Contact

Gaming



For the past decade or so, gaming on the PC has skyrocketed to new heights. Computers designed and built for gaming are one of the most common types of computers in the market. Even though gaming consoles have a very strong presence in the gaming market, gaming PCs are still running strong in today's market. The major reason why is because there are many retail and custom PCs that over-power current consoles. Some of these benchmark gaming computers can put current consoles to shame.

Arguably this most important unique components of this type of computer is the graphics card, or GPU. For most other computers you do not need a graphics card. But for gaming in particular, a graphics card is needed to allow all of today's latest graphic technology. You could just as easily buy a prebuilt computer to play games, but technology changes and advances every year and eventually you'll need to upgrade your computer to play new games that come out.

Games that are multiplatform, or released on most gaming consoles and computers, tend to be of better quality on a computer than consoles. This is because game developers can accomplish much more using the latest in computer technology compared to the limitations that consoles have. Although most users traditionally use a keyboard and mouse to play computer games, gamepads, touchscreens, and motion controllers can also be used if the game is programmed to use it.

Since all computers are not sold by a particular group, games, software, and services are sold more cheaply than consoles because of the competition between the manufacturers and companies. PC games decades old can be played on current systems using emulation software if need be. The openness that the PC allows players to edit some of their games and distribute the results over the internet as modifications, or "mods". A healthy mod community greatly increase a game's life span and the most popular mods have driven purchases of their parent game to record heights.

PC Builders Site Map
 Search by page name

Home Why Should I? Components Build a PC Contact

Internet/E-mail



The internet itself has gone through such staggering changes in the past ten years that it has been thoroughly integrated into many aspects of our life. Luckily, you don't have to buy many expensive computer parts to make your surfing experience the best it can be. The only components in your computer that govern your internet connection capabilities are the motherboard, CPU, RAM, Hard Drive speed, and NIC (Network Interface Controller) if you have one. There are also other elements outside your computer you must consider when trying to get better internet, like the ethernet cable, router, and internet provider.

This type of computer is normally used to just connect and communicate with other users around the world. If you optimize your computer and internet connection, you might still run into issues connecting with people. Not everyone takes the time to optimize these things so you might have problems connecting with them. That being said, making sure you have the optimal internet speed prevents you from having connection problems with users overall.

The Ethernet capabilities of a computer are either integrated into the motherboard chipset or implemented via a low-cost dedicated Ethernet chip, connected through the PCI or PCI Express bus. A separate network card is not required unless you need additional interfaces or you are making some other type of computer network.

Post Comment

Type your comments about this article here. Use coherent and complete sentences with preferably no typos or misspellations.

PC Builders Site Map
 Search by page name

Home Why Should I? Components Build a PC Contact

Multimedia



Other very popular uses for a computer are creating graphics, animation, interactive elements, video and audio. Nowadays there are many programs that help you immerse in creating one or nearly all of these things. Depending on what programs you want to use and what you want to create, your computer may need certain components to be higher-end in order to run properly.

Since most of the multimedia uses for a computer are graphical, you will need a good graphics card to render those graphics you will make properly. A higher-end CPU and RAM will also be needed to allow your computer to handle more graphics and animation you may need to add. A large hard drive will allow you to save huge graphics and animation files that you will make. Animation and 3D graphics will need these things especially in order to run smoothly.

2D graphics and audio are less performance intensive for the most part but you should still consider getting a good CPU, RAM, graphics card, and sound card (for audio) with a large hard drive. If you want more focus on audio, focus on getting a good audio card and sound system to do audio testing.

Post Comment

Type your comments about this article here. Use coherent and complete sentences with preferably no typos or misspellations.

PC Builders Site Map
 Search by page name

Home Why Should I? Components Build a PC Contact

Word Processing



Word processing is very important for writers, accountants, students and journalists. With word processing applications you can also create legal copies, memos, reference documents, resumes, greeting cards, letters and reference among other important documents. Luckily, running these applications doesn't require extraordinary components in order to run them.

No components are specifically needed for this type of computer. The only things that are necessary are a decent CPU, a couple of gigabytes of RAM, and a good-sized hard drive. A fancy graphics card, NIC, or audio card is unnecessary since you are only dealing with words most of the time.

Post Comment

Type your comments about this article here. Use coherent and complete sentences with preferably no typos or misspellations.

PC Builders Site Map
 Search by page name

Home Why Should I? Components Build a PC Contact

Components

Motherboard



A motherboard (also known as the mainboard, system board, planar board or logic board) is the main printed circuit board found in computers.

CPU/Processor

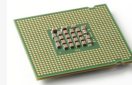

A CPU (Central Processing Unit) is the two to three inch chip within a computer that carries out the instructions of a computer program by performing the basic arithmetical, logical and input/output operations of the system.



Quintin Jackson | Web Developer | qweb.com

PC Builders Site Map

Home Why Should I? Components Build a PC Contact

Build a PC: Overview

Open Chassis and Secure Motherboard

Secure Hard Drive(s)

Install NIC Card(s)

Connect Peripherals

Latch in CPU and Connect Fan

Secure Optical Drive(s)

Test Computer and Close the Chassis

Lock in RAM

PC Builders Site Map

Home Why Should I? Components Build a PC Contact

Build a PC Part 1

Open Chassis and Secure Motherboard

Latch in CPU and Connect Fan

Lock in RAM

Move on to Part 2

Make sure to know which side to open the case from. Usually, the side that has a vent is the side to open from.

Find a square socket about two inches across with a cover and latch. This is the CPU socket that the CPU goes into. Take note of any small notches or a triangle symbol or notch in one corner of the socket.

Find the RAM slots on the motherboard. They are long, really thin slots with little lock tabs located next to the CPU.

PC Builders Site Map

Home Why Should I? Components Build a PC Contact

Build a PC Part 2

Secure Hard Drive(s)

Secure Optical Drive(s)

Connect Power Cables

Move on to Part 3

Hook the bar to a small metal hook on the side of the CPU socket.

Find the RAM slots on the motherboard. They are long, really thin slots with little lock tabs located next to the CPU.

PC Builders Site Map

Home Why Should I? Components Build a PC Contact

Build a PC Part 3

Go Back to Overview

Install NIC Card(s)

Connect Peripherals

Test Computer and Close the Chassis

Make sure to know which side to open the case from. Usually, the side that has a vent is the side to open from.

Connect keyboard, mouse, monitor, and whatever peripherals you need to navigate your computer.

When you test your computer you may want to navigate your computer to do certain things like download and install your graphics card software to intimately test the graphics card.

Lay the chassis on its side with the side that you want to open facing up. Take note on the back of what chassis unit

PC Builders Site Map

Home Why Should I? Components Build a PC Contact

Contact Page

This is the contact page where you can report any problems or ask questions about the website.

First Name:

Last Name:

Email:

Confirm Email:

What type of issue are you writing about?

Please leave your issues/concerns below:

Type your message here, use shorthand and complete sentences when preferable no shorthand or chat abbreviations.

PC Builders Site Map

Home Why Should I? Components Build a PC Contact

Site Map

Home

Why Should I?

- Gaming
- Internet/E-mail
- Multimedia
- Word Processing

Components

- Motherboard
- CPU/Processor
- RAM
- GPU/Graphics Card
- NIC/Network Interface Card
- Sound Card
- Hard Drive
- Power Supply



Quintin Jackson | Web Developer | qweb.com



Quintin Jackson
Web Developer
qweb.com